



HIGH PERFORMANCE POOL PUMP

HERCULES

Ultra-silent and robust residential pool pump HERCULES.

Designed for any type of residential pool, ideal for salt chlorinators or sea water. Can even work at high temperatures, maximum 60°C .

Monophasic & Triphasic 50-60Hz. Available from 0,33 Hp to 1,50 Hp.

FEATURES:

- Durability and Robustness.
- Shaft in Stainless steel AISI 316L.
- Anti-vibration bearings.
- Viton seals: excellent resistance to chemical agents.
- Silicon carbide mechanical seal.
- Impeller in Noryl with fiberglass
- Insulation class F. Supplied with unions: Ø50 mm" thread of 1½".

✓ Energy Savings and Efficiency.

For maximum performance at a low cost, we have models with energy efficiency class IE3.



✓ Robust and transparent lid for quick inspection.



✓ Reinforced base for stability.



✓ High capacity prefilter to prevent cleaning so often and easy to open.

CODE	POWER (hp)	POWER (KW)	INTENSITY (A)	VOLTAGE (V) 50Hz or 60Hz	WEIGHT (kg)	PACKAGING SIZE LxWxH
NDE-H033M	0,35	0,25	1,6	220-240	8,10	535x225x325
NDE-H050M	0,50	0,37	2	220-240	9,30	
NDE-H075M	0,75	0,55	3,2	220-240	10,60	
NDE-H075T	0,75	0,55	$\Delta 1,7/Y1,0$	230/400	10,60	
NDE-H100M	1,00	0,75	3,8	220-240	11,40	
NDE-H100T	1,00	0,75	$\Delta 2,4/Y1,4$	230/400	11,40	
NDE-H150M	1,50	1,1	5,8	220-240	12,80	
NDE-H150T	1,50	1,1	$\Delta 3,6/Y2,1$	230/400	12,80	

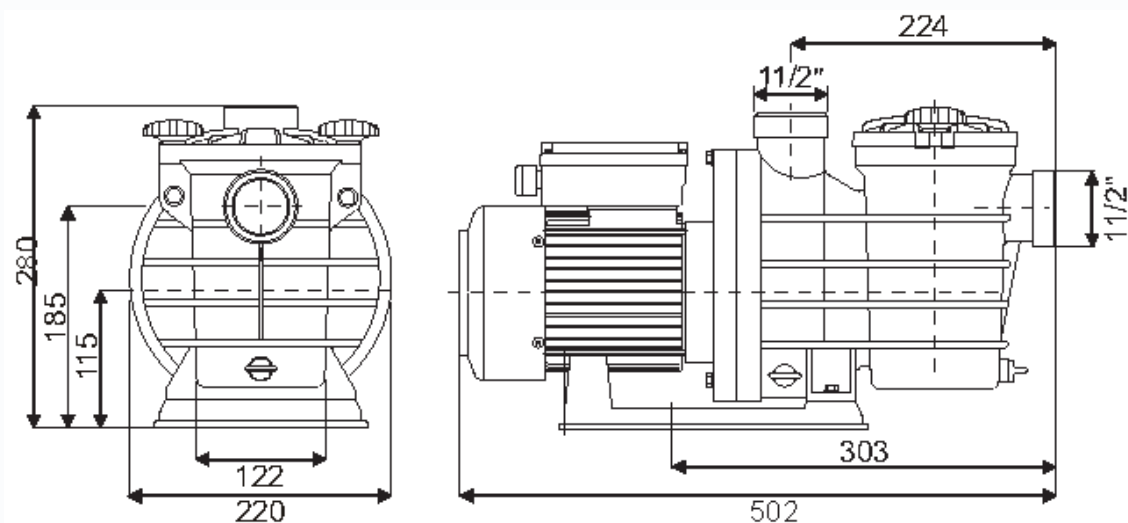
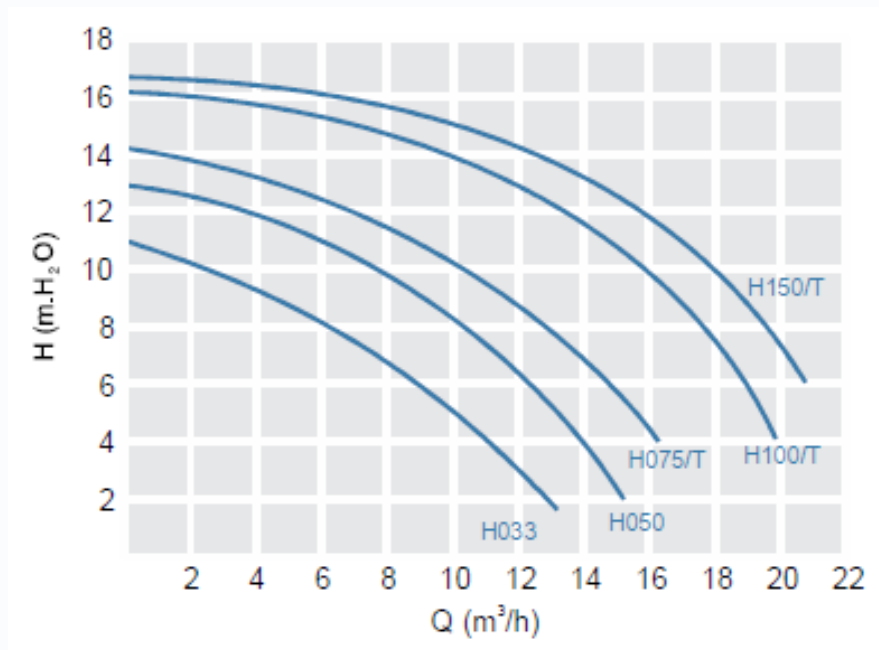

We reserve the right to change all or part of the features of the articles or contents of this document, without prior notice.