



HIGH PERFORMANCE POOL PUMP



PEGASO

Our pool pump PEGASO, is ultra-silent and it offers an state-of-the-art performance thanks to the development carried out by our engineers and its high-quality components.

Robust design for the highest demands on power and efficiency. For any type of residential pool, both seawater, salt chlorination or chlorine, working even at temperatures of 60°C.

FEATURES:

- Durability and Robustness.
- Shaft in Stainless steel AISI 316L.
- Anti-vibration bearings.
- Viton seals: excellent resistance to chemical agents
- Silicon carbide mechanical seal.
- Impeller in Noryl with fiberglass.
- Insulation class F. Supplied with unions: Ø63 mm" thread of 2".

✓ Energy Savings and Efficiency.

For maximum performance at a low cost, we have models with energy efficiency class IE3.



✓ Robust and transparent lid for quick inspection.



✓ Reinforced base for stability

✓ High capacity prefilter to prevent cleaning so often and easy to open.



CODE	POWER hp	POWER kW	LEVEL dBA	INTENSITY A	VOLTATGE 50/60Hz	L mm	WEIGHT kg	PACKAGING SIZE LxWxH mm
NDE-P075M	0,75	0,55	60	3,2	220-240	628	14,6	635x275x350
NDE-P075T	0,75	0,55	60	$\Delta 1,7/Y1,0$	230/400	628	14,6	635x275x350
NDE-P100M	1,00	0,75	64	3,8	220-240	628	16,0	635x275x350
NDE-P100T	1,00	0,75	64	$\Delta 2,4/Y1,4$	230/400	628	16,0	635x275x350
NDE-P150M	1.50	1,10	68	5,2	220-240	628	17,3	635x275x350
NDE-P150T	1.50	1,10	68	$\Delta 3,6/Y2,1$	230/400	628	17,3	635x275x350
NDE-P200M	2,00	1,50	72	7,0	220-240	628	21,0	635x275x350
NDE-P200T	2,00	1,50	72	$\Delta 4,5/Y2,6$	230/400	628	21,0	635x275x350
NDE-P300M	3,00	2,20	75	10,0	220-240	646	24,1	670x275x350
NDE-P300T	3,00	2,20	75	$\Delta 7,1/Y4,1$	230/400	646	24,1	670x275x350

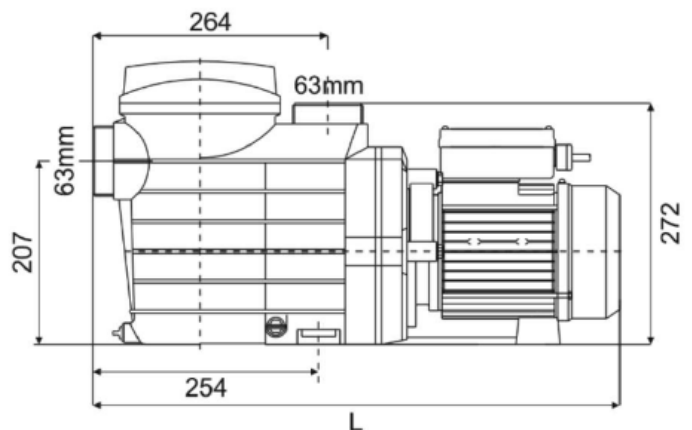
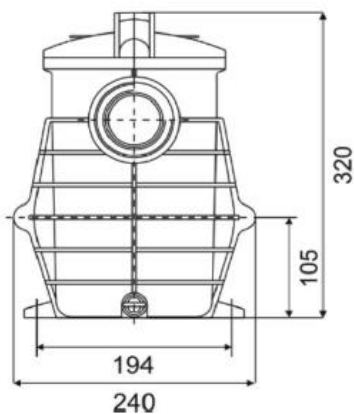
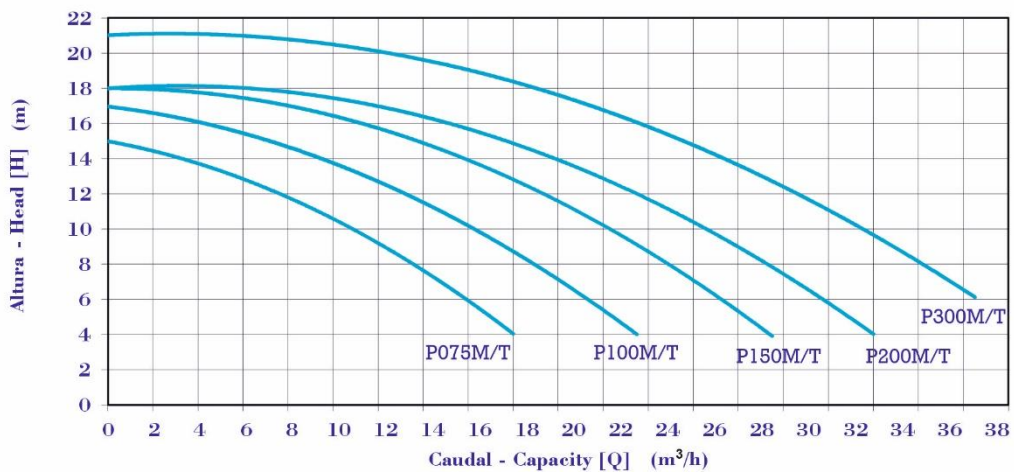

We reserve the right to change all or part of the features of the articles or contents of this document, without prior notice.